



# DESIGN NOTES

## 10 $\mu$ A Quiescent Current Step-Down Regulators Extend Standby Time in Handheld Products – Design Note 235

Greg Dittmer

### Importance of Low Quiescent Current

Many handheld products on the market today are used only occasionally but must be kept alive and ready all the time. When not being used, the circuitry is powered down to save battery energy, with a minimum amount of circuitry remaining on. Although the supply current is significantly reduced in this low power standby mode, the battery energy will still be slowly depleted to power the keep-alive circuitry and the regulator. If the device spends most of its time in this standby mode, the quiescent current of the regulator can have a significant effect on the life of the battery (see Figure 1).

To maximize the life of the battery in these types of products, Linear Technology has extended its family of 10 $\mu$ A step-down regulators to provide three new products. The LTC<sup>®</sup>1771 is a constant off-time controller that drives an external P-channel MOSFET for output loads up to 5A. The LTC1877 and LTC1878 are monolithic regulators that provide constant frequency (550kHz) plus synchronous operation for loads up to 600mA. Due to their micropower architecture, the LTC1771, LTC1877 and LTC1878 require only 10 $\mu$ A of supply current to regulate their output at no load. These converters also feature micropower shutdown, current mode operation for excellent transient response and start-up behavior, short-circuit protection, 100% duty cycle for low dropout, availability in the tiny MSOP package and Burst Mode™

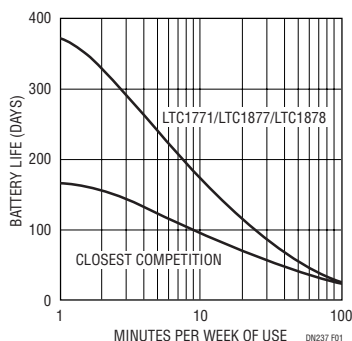

**Figure 1. 9V Battery Life Comparison for Load Requiring 100mA Operating and 100 $\mu$ A Standby Current at 3.3V**

operation disable for low noise applications. The features of each of these parts are summarized in Table 1.

**Table 1. Summary of Features of the LTC1771, LTC1877 and LTC1878**

	LTC1771	LTC1877	LTC1878
No Load I <sub>Q</sub>	10 $\mu$ A	10 $\mu$ A	10 $\mu$ A
Architecture	Controller	Monolithic	Monolithic
Maximum Load	Up to 5A (Programmable)	600mA (Fixed)	600mA (Fixed)
Input Supply Range	2.8V to 20V	2.65V to 10V	2.65V to 6V
Shutdown Current	2 $\mu$ A	< 1 $\mu$ A	< 1 $\mu$ A
Max Duty Cycle	100%	100%	100%
Package	MS8, SO-8	MS8	MS8
Frequency	3.5 $\mu$ s Off Time	550kHz	550kHz
Synchronous Rect	No	Yes	Yes
Synchronizable	No	Yes	Yes

### LTC1878 Single Li-Ion to 2.5V Regulator

Figure 2 shows an application for converting a single cell Li-Ion to 2.5V at 600mA using the LTC1878. The internal synchronous switch, along with its 550kHz constant frequency operation, eliminates the need for an external Schottky diode and allows the use of small surface mount inductors and capacitors, saving external components and space. For higher input voltages such as dual Li-Ion

Ⓢ, LTC and LT are registered trademarks of Linear Technology Corporation. Burst Mode is a trademark of Linear Technology Corporation.

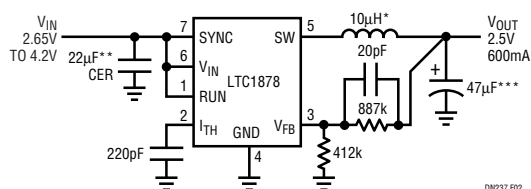

\* TOKO D62CB A920CY-100M  
 \*\* TAIYO-YUDEN CERAMIC LMK325BJ106MN  
 \*\*\* SANYO POSCAP 6TPA47M

**Figure 2. LTC1878 2.5V/500mA Regulator**

applications, the LTC1877 can be used. The efficiency curves for this regulator are shown in Figure 3 and due to its ultralow quiescent current, the regulator provides outstanding efficiency down to loads as little as 100 $\mu$ A.

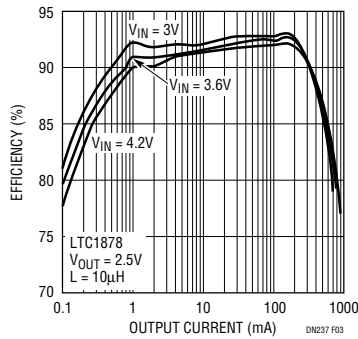

Figure 3. Efficiency vs Load Current for Figure 2's Circuit

### LTC1771 3.3V/2A Regulator

For higher load currents or higher supply voltages with similar outstanding light load efficiency, the circuit shown in Figure 4 can be used. This circuit uses the LTC1771 controller which, when used with the appropriately sized external P-channel MOSFET, can provide output loads up to 5A. Due to the wide operating voltage of the LTC1771, the 3.3V/2A regulator shown in Figure 4 can operate with an input supply up to 18V. The 2A maximum load current is programmed with the 0.05 $\Omega$  sense resistor. With a 15 $\mu$ H inductor and low ESR POSCAP output capacitor, the output ripple is less than 50mV. The Siliconix Si6447 or Si3443 are good MOSFET choices for the appropriate supply range due to their good compromise between low gate charge and low  $R_{DS(ON)}$ , while the Microsemi Powermite UPS5817 Schottky diode provides a good compromise between

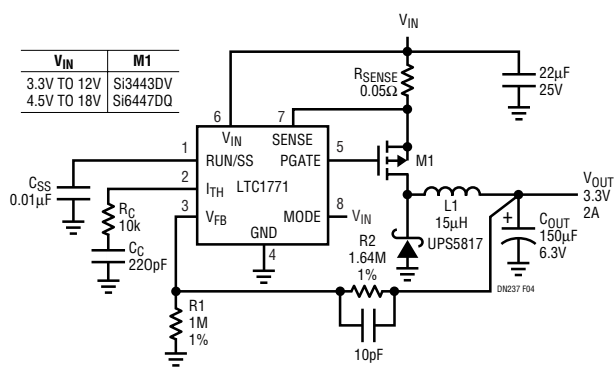

Figure 4. LTC1771 3.2V/2A Regulator

#### Data Sheet Download

<http://www.linear-tech.com/go/dnLTC1771>  
<http://www.linear-tech.com/go/dnLTC1877>

forward drop and reverse leakage. Low reverse leakage in the Schottky diode is important because the leakage current can potentially exceed the 10 $\mu$ A quiescent current of the LTC1771, thus significantly increasing the regulator's no load supply current. Unfortunately, Schottky diodes with lower reverse leakage tend to have higher forward drops and forward voltage drop affects efficiency at moderate to high loads. The efficiency curves for this regulator (Figure 5) show outstanding efficiency across more than four decades of load current.

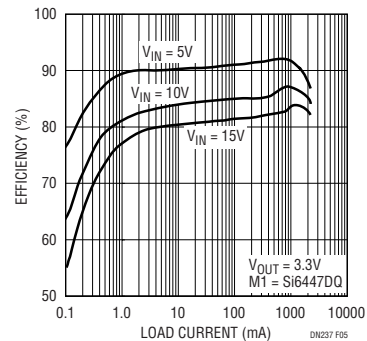

Figure 5. LTC1771 Efficiency vs Load Current for Figure 4's Circuit

### Low Operating Current Without Compromising Transient Response

Just because the LTC1771, LTC1877 and LTC1878 use so little supply current doesn't mean the transient performance is compromised. Innovative new circuitry ensures that the error amplifier, while operating on less than 10 $\mu$ A at no load, can quickly respond to load changes. The oscilloscope photo shown in Figure 6 shows the outstanding transient performance of the LTC1878 regulator of Figure 2 when subjected to a 500mA load step.

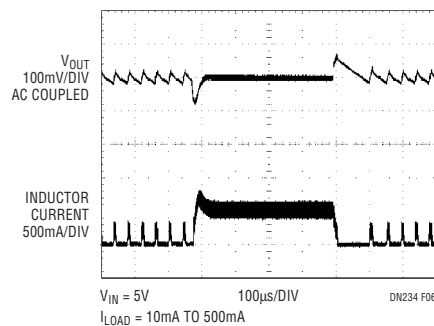

Figure 6. Load Step Transient Response for Figure 2 Circuit

For literature on our DC/DC Controllers, call **1-800-4-LINEAR**. For applications help, call (408) 432-1900, Ext. 2681